

# KITZ

# XJ Series Aluminum Butterfly Valves



KITZ CORPORATION

# Aluminum Butterfly Valves

## XJ Series

KITZ XJ Series aluminum butterfly valves : Featured with unique style of the neck designs (U.S.P. No.6676109) , for accommodation of various piping designs, piping positions and installation environments.

Neckless



Short Neck



Long Neck



### **Three neck designs for your choice :**

Long neck type, short neck type and neckless type are available for versatile applications.

### **Easy valve-to-flange centering :**

Light weight of die-cast aluminum valve body (which is only one-thirds of KITZ's conventional cast iron butterfly valves) eases valve-to-flange centering work on mounting valves on pipelines.

### **Wide range of service applications :**

Austenitic stainless steel discs and EPDM rubber seats can handle many different kinds of line fluid without concern of corrosion.

### **Stabilized operating torque :**

A pair of stem bearing assembled around the top and bottom stems prevents stem galling, and stabilizes valve operating torque for smooth and trouble-free disc rotation.

### **On-the-spot actuator assembly :**

The actuator mounting pads of all necks are designed in conformity with ISO 5211 requirements for direct on-site mounting of actuators which are provided with ISO 5211 valve mounting flanges.



### **Prevention of dew condensation (Long neck type) :**

A long stainless steel neck blocks transfer of the fluid heat to a valve operating device, which thus needs no insulation on the operating device. Dew condensation is minimized also in case of gear operated valves on cold water service.

### **Rust prevention :**

Main parts such as stems, discs, necks, neck connectors and endplates, and small parts such as stopper plates, washers and boltings are all made of stainless steel for highly graded rust prevention.

### **S-shape spherical disc for high sealing performance (patented) :**

KITZ's original cross-sectionally S-shaped valve discs with spherical surface evenly make tight contact with rubber liners for excellent sealing performance with reduced operating torque. Thorough 360° shut-off mechanism helps extend service life of rubber liners. (Size 2inch and over.)



3ADG12

### Long Neck Type

Prevented dew condensation



- A long stainless steel neck reduces conductivity of the fluid heat for prevention of dew condensation.
- Availability of valve body and neck insulation.
- Choice of actuators for automated valve operation.

#### Applications:

- Building utilities .
- Piping networks for cold water, hot water and other water supply.

### Short Neck Type

Compact design



- Suitable for piping in a limited space.
- Choice of actuators for automated valve operation.

#### Applications:

- Building utilities.
- Plant facilities.
- Water treatment service.
- Operation of industrial machineries.

### Neckless Type

Built-in operation mechanism  
(Driven with a socket wrench)



- Suitable for less frequent on-off operation.
- Suitable for piping in a limited space.
- Availability of valve body insulation.
- Prevention of unauthorized and unintentional operation.

#### Applications:

- Building utilities.
- Plant facilities.
- Water treatment service.
- Operation of industrial machineries.

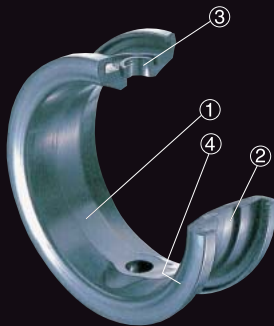

**Elaborately designed KITZ EPDM seats are featured with the following uniqueness for functional stability, high sealing performance and long life cycle:**

- Self-reinforcing back-ribs
- Wider disc seating contact
- Dual stem seal bearings

- ① Wider disc seating contact for high sealing performance.
- ② Reinforcing back-ribs to minimize valve operating problems such as distortion, skidding and exfoliation of rubber liners caused by line pressure load and friction with metal discs.
- ③ Stem seal bearings are assembled on top and bottom stems for stabilized sealing function.
- ④ Gasketless flange sealing contact for easy valve mounting.

## Product Range

● Standardized. ○ Optionally available.

Design	Class	Operator	Size Product code	Size												Page		
				mm	40	50	65	80	100	125	150	200	250	300				
				inch	1½	2	2½	3	4	5	6	8	10	12				
Long neck	JIS 10K	Lever	10XJME	○	○	○	○	○	○	○	○	○	○	○	○	○	6	
		Gear	G-10XJME	○	○	○	○	○	○	○	○	○	○	○	○	○	●	6
		Pneumatic actuator (Double action)	FA-10XJME	○	○	○	○	○	○	○	○	○	○	○	○	○	○	9
		Pneumatic actuator (Spring return)	FAS-10XJME	○	○	○	○	○	○	○	○	○	○	○	○	○	○	9
		Electric actuator	EXS-10XJME	○	○	○	○	○	○	○	○	○	○	○	○	○	○	11
	JIS 10K/ ASME Class 150	Lever	10XJMEA	●	●	●	●	●*	●*	●	●	●	●*	○	○	○	○	6
		Gear	G-10XJMEA	●	●	●	●	●*	●*	●	●	●	●*	●	○	○	○	6
		Pneumatic actuator (Double action)	FA-10XJMEA	○	○	○	○	○*	○*	○	○	○	○*	○	○	○	○	9
		Pneumatic actuator (Spring return)	FAS-10XJMEA	○	○	○	○	○*	○*	○	○	○	○*	○	○	○	○	9
		Electric actuator	EXS-10XJMEA	○	○	○	○	○*	○*	○	○	○	○*	○	○	○	○	11
	EN1092 PN16	Lever	PN16XJME	○	●	●	●	●**	●	●	●	●	○	○	○	○	○	6
		Gear	G-PN16XJME	○	●	●	●	●**	●	●	●	●	●	●**	○	○	○	6
	Short neck	JIS 10K	Lever	10XJSME	○	●	●	●	●	●	●	●	○	○	○	○	○	7
			Gear	G-10XJSME	○	●	●	●	●	●	●	●	●	●	○	○	○	7
Pneumatic actuator (Double action)			FA-10XJSME	○	○	○	○	○	○	○	○	○	○	○	○	○	○	9
Pneumatic actuator (Spring return)			FAS-10XJSME	○	○	○	○	○	○	○	○	○	○	○	○	○	○	9
Electric actuator			EXS-10XJSME	○	○	○	○	○	○	○	○	○	○	○	○	○	○	11
Neckless	JIS 10K	(Socket wrench)	N-10XJSME	○	○	○	○	○	○	○	○	○	○	○	○	○	8	

\* Centering sleeves are optionally available for accurate centering with ASME class 150 flanges.  
 \*\*Centering sleeves are supplied for accurate centering with EN1092 PN16 flanges.

## Product Coding

**G-10 XJ S M E A**

①      ②      ③      ④      ⑤      ⑥      ⑦

### ① Valve operation

None ..... Lever  
 G ..... Gear  
 FA ..... Pneumatic actuator (Double action)  
 FAS ..... Pneumatic actuator (Spring return action)  
 EXS ..... Electric actuator (Please consult KITZ for availability of power supply)  
 N ..... Socket wrench type

### ② Class

10 ..... JIS 10K  
 10\_A ..... JIS 10K/ASME Class 150  
 PN16 ..... EN1092 4504 PN16

### ③ KITZ Butterfly valve series

XJ ..... XJ series

### ④ Design

None ..... Long neck  
 S ..... Short neck

### ⑤ Disc material

M ..... 316 stainless steel

### ⑥ Seat material

E ..... EPDM

## Technical Specification

Class	JIS 10K	Class 150	PN16
Maximum service pressure	1MPa	1MPa	1.6MPa (16bar)
Service temperature range*1	-20°C~+120°C		
Continuous service temperature range*2	0°C~+100°C		
Face-to-face dimension	API609, BS5155 (Short pattern) ISO 5752-20, JIS B 2002 46 series		
Coupling flanges	JIS B 2220 / 2239 10K	ASME Class 150 JIS B 2220 / 2239 10K	EN1092 PN16*3

\*1 Condition : Fluid is not frozen.

\*2 Refer to P-T rating chart.

\*3 With centering sleeves.

Refer to the product range chart in page 3 and precaution in page 14 for details.

## P-T Rating

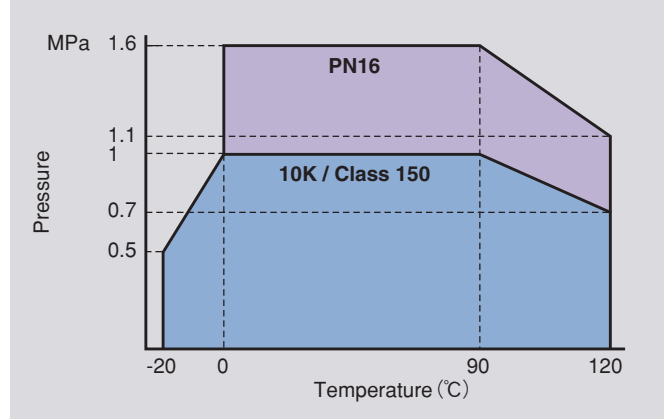

Note : Contact KITZ corporation for technical advice when service conditions may exceed the P-T rating range limited here.

## Cv Value

Valve size		Valve opening
mm	inch	90°
40	1½	76
50	2	99
65	2½	205
80	3	372
100	4	723
125	5	1100
150	6	1820
200	8	2780
250	10	4350
300	12	6860

## Pressure Loss (for handling static clean water)

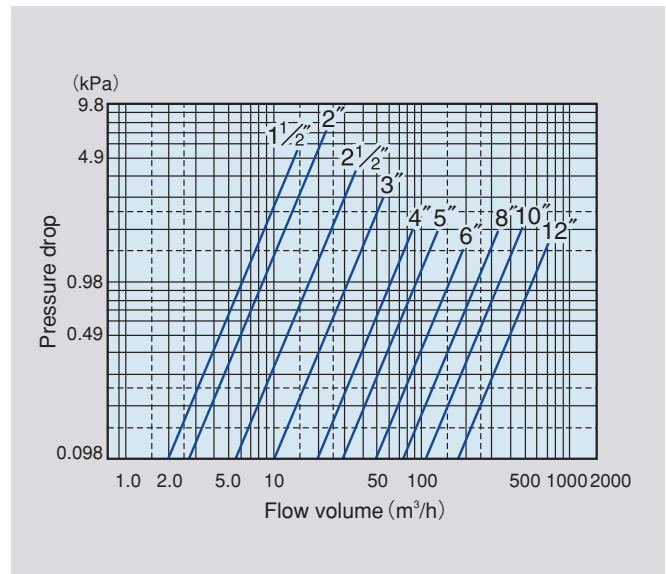

## Flow Characteristics

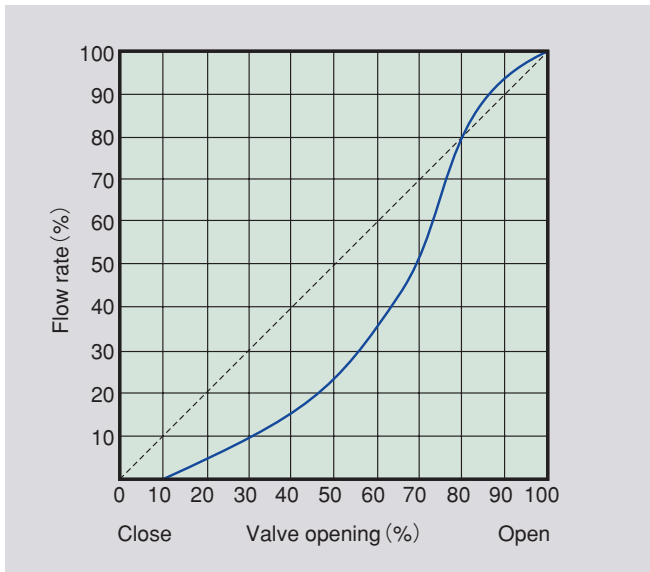

## Material

Parts	Material
Body	Aluminum Die-cast / Equivalent ASTM B85-84-383.0
Neck	A351 Gr. CF8
Stem	(Equivalent ASTM A276 Type 410)
Disc	A351 Gr. CF8M
O-ring	EPDM
Rubber seat	EPDM
Bottom stem	(Equivalent ASTM A276 Type 410)
Bearing	Metal Backed PTFE (Size 10" and 12") Polyphenylenesulfide (10XJMEA : Size 1½" to 8") Bronze : CAC401C (PN16XJME : Size 2" to 8")



## Dew Condensation Test

Samples of KITZ XJ Series butterfly valves equipped with long necks (KITZ Product Code : G-10XJMEA) were tested at KITZ laboratory under the conditions introduced below. Lower surface temperature of gear boxes, atmospheric temperatures and atmospheric humidities were measured as the variable functions. The dew condensations boundary was estimated as illustrated below.

### Test condition :

Line fluid : +5°C cold water  
 Atmospheric temperature : +20°C to +40°C  
 Valve insulation : 50mm glass wool (JIS A 9501) around the test valve with gear boxes exposed to the open air.

### Note:

The estimation introduced here is a result of summary of the tests carried out within a test basin provided with constant temperature and humidity, and does not necessarily represent absolute values. Note that dew condensation preventative property of these valves may be affected by change of test environments such as extent of air transfer and variation of line fluid temperature, atmospheric humidity or condition of insulation. Thus, acceptance of allowance of ±5% over the boundary area is recommended.

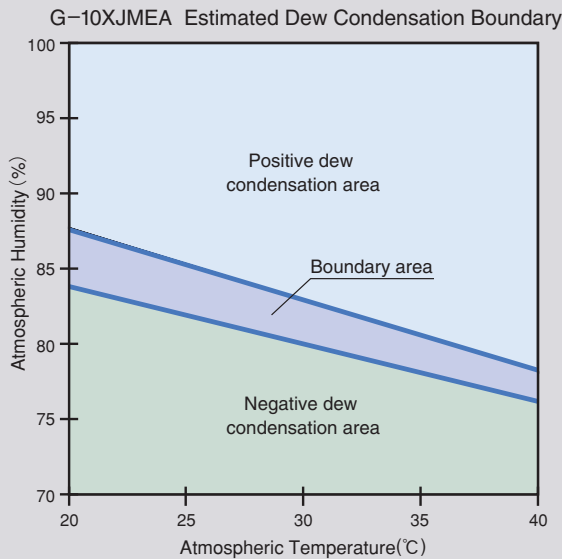

## Valve Insulation

Areas in blue are recommended to insulate

**Long Neck Type**  
(G-10XJMEA)

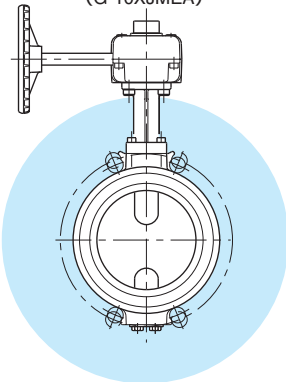

**Neckless Type**  
(N-10XJSME)

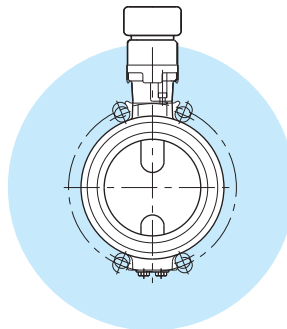

## Corrosion Resistance Level

This table indicates general corrosion resistance level of the materials of discs and rubber liners used for KITZ XJ Series butterfly valves against typical line fluids. The data is based on the laboratory test finding on **material test specimens** (not valve component test specimens) under constantly controlled test conditions, and thus each data may be subject to variation, depending on actual valve service conditions in the field. Please contact KITZ Corporation for technical advice, if service conditions are extra-ordinarily severe, or you have any doubt about corrosion resistance level of valves on-site. Also please contact KITZ Corporation when valves are used for hot water service.

- = Excellent
- = Good
- △ = Less recommended
- × = Not recommended

Fluid	Materials	Disc material	Seat material
		CF8M	EPDM
Acetic acid (10%)		●	●
Air		●	●
Ammonia (anhydrous liquid)		●	●
Ammonium sulfate		●	●
Animal fat		●	×
Calcium chloride		●	●
Carbonic acid		●	●
Chlorinated water		△	×
Ethane		●	×
Ethyl alcohol		●	●
Freon 12		●	●
Gasoline (refined / unleaded)		●	×
Hydrochloric acid 37% (cold)		×	●
Hydrogen gas (cold)		●	●
Lubricating oil (petroleum base)		●	×
Methyl alcohol		●	●
Mineral oil		●	×
Heavy oil		●	×
Natural gas		●	×
Oxygen (cold)		●	●
Petroleum oil (refined)		●	×
Propane gas		●	×
Sea water		●	●
Soybean oil		●	△
Sulfuric acid (7%)		△	●
Sulfuric acid (20%)		×	●
Sulfuric acid (50≥%)		×	●
Sulfurous		●	△
Steam (100°C)		●	●
Vegetable oil		●	△
Water (fresh) *		●	●

\* Chlorine-free

**Long Neck Type** *Lever Operated*

10XJME (Size: "1½" to "6")  
 10XJMEA (Size: "1½" to "8")  
 PN16XJME (Size: "2" to "6")

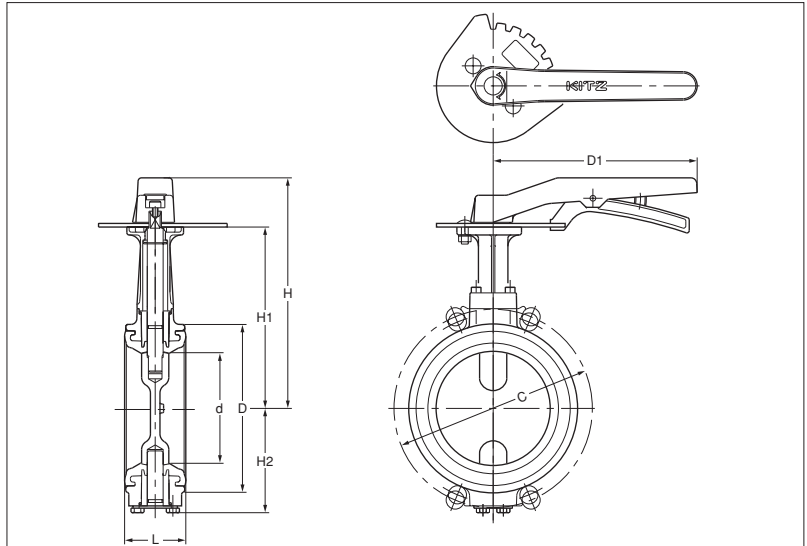

■ Dimensions

unit : mm

Size		d	H	H1	H2	L	D	C			D1
mm	inch							10K	Class 150	PN16	
40	1½	40	172	128	40	33	80	105	98.5	—	180
50	2	50	176	132	66	43	93	120	120.5	125	180
65	2½	65	185	141	74	46	118	140	139.5	145	180
80	3	80	193	149	83	46	129	150	152.5	160	180
100	4	100	204	160	94	52	149	175	190.5	180	180
125	5	125	249	195	122	56	184	210	216	210	230
150	6	150	261	207	135	56	214	240	241.5	240	230
200	8	196	281	234	161	60	259	—	298.5	—	350

**Long Neck Type** *Gear Operated*

G-10XJME (Size: "1½" to "12")  
 G-10XJMEA (Size: "1½" to "10")  
 G-PN16XJME (Size: "2" to "8")

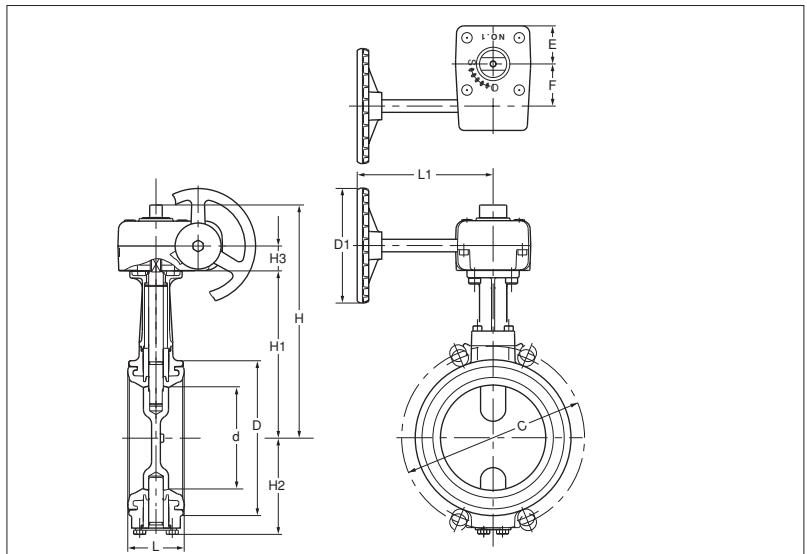

■ Dimensions

unit : mm

Size		d	H	H1	H2	H3	L	D	C			D1	L1	E	F	Gear type
mm	inch								10K	Class150	PN16					
40	1½	40	175	128	40	19	33	80	105	—	—	80	122	29	28	No.0
50	2	50	179	132	66	19	43	93	120	120.5	125	80	122	29	28	No.0
65	2½	65	188	141	74	19	46	118	140	139.5	145	80	122	29	28	No.0
80	3	80	196	149	83	19	46	129	150	152.5	160	80	122	29	28	No.0
100	4	100	223	160	94	24	52	149	175	190.5	180	110	135	36	40	No.1
125	5	125	258	195	122	24	56	184	210	216	210	110	150	36	40	No.1
150	6	150	270	207	135	24	56	214	240	241.5	240	110	150	36	40	No.1
200	8	196	311	234	161*1	32	60	258	290	298.5	295	170	180	51	63	No.2
250	10	245	405	328	238	32	68	316	355	362	—	170	180	51	63	No.2
300	12	295	430	353	263	32	78	367	400	—	—	170	180	51	63	No.2

\*1 G-PN16XJME H2=183

**Short Neck Type** *Lever Operated*

10XJSME

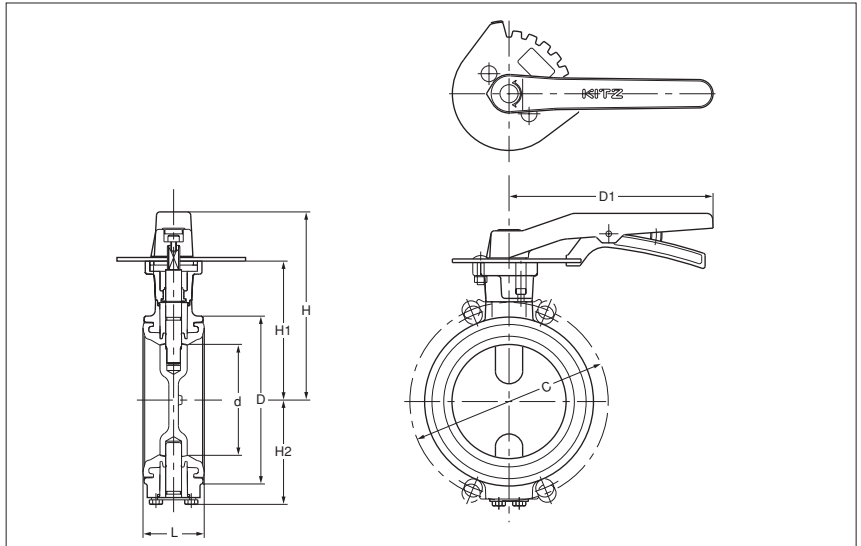

■ Dimensions

unit : mm

Size		d	H	H1	H2	L	D	C	D1
mm	inch								
40	1½	40	137	93	40	33	80	105	180
50	2	50	139	95	66	43	93	120	180
65	2½	65	147	103	74	46	118	140	180
80	3	80	156	112	83	46	129	150	180
100	4	100	167	123	94	52	149	175	180
125	5	125	205	151	122	56	184	210	230
150	6	150	217	163	135	56	214	240	230

**Short Neck Type** *Gear Operated*

G-10XJSME

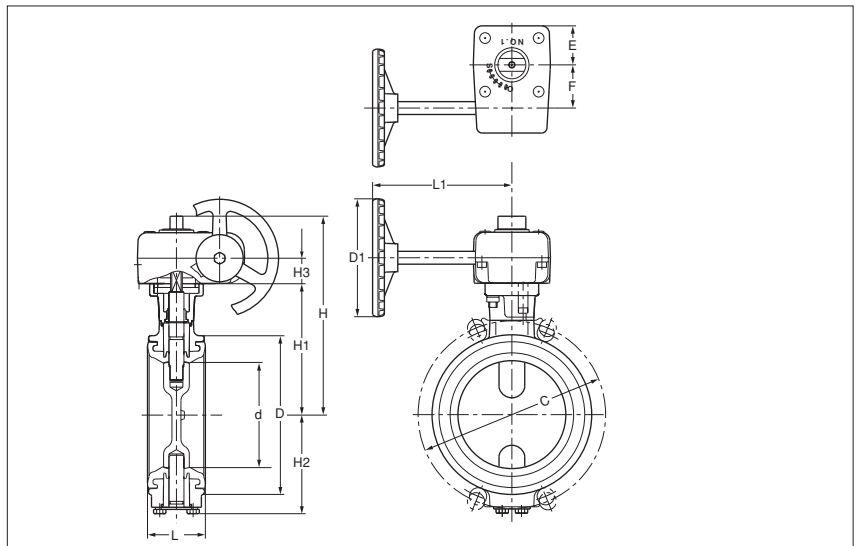

■ Dimensions

unit : mm

Size		d	H	H1	H2	H3	L	D	C	D1	L1	E	F	Gear type
mm	inch													
40	1½	40	140	93	40	18.5	33	80	105	80	121.5	29	28	No.0
50	2	50	142	95	66	18.5	43	93	120	80	121.5	29	28	No.0
65	2½	65	150	103	74	18.5	46	118	140	80	121.5	29	28	No.0
80	3	80	159	112	83	18.5	46	129	150	80	121.5	29	28	No.0
100	4	100	186	123	94	23.8	52	149	175	110	135	36.4	40.3	No.1
125	5	125	214	151	122	23.8	56	184	210	110	150	36.4	40.3	No.1
150	6	150	226	163	135	23.8	56	214	240	110	150	36.4	40.3	No.1
200	8	196	267	190	161	32	60	258	290	170	185	51	62.9	No.2
250	10	245	317	239	238	32	68	316	355	170	180	51	63	No.2
300	12	295	342	264	263	32	78	367	400	170	180	51	63	No.2



**N-10XJSME**

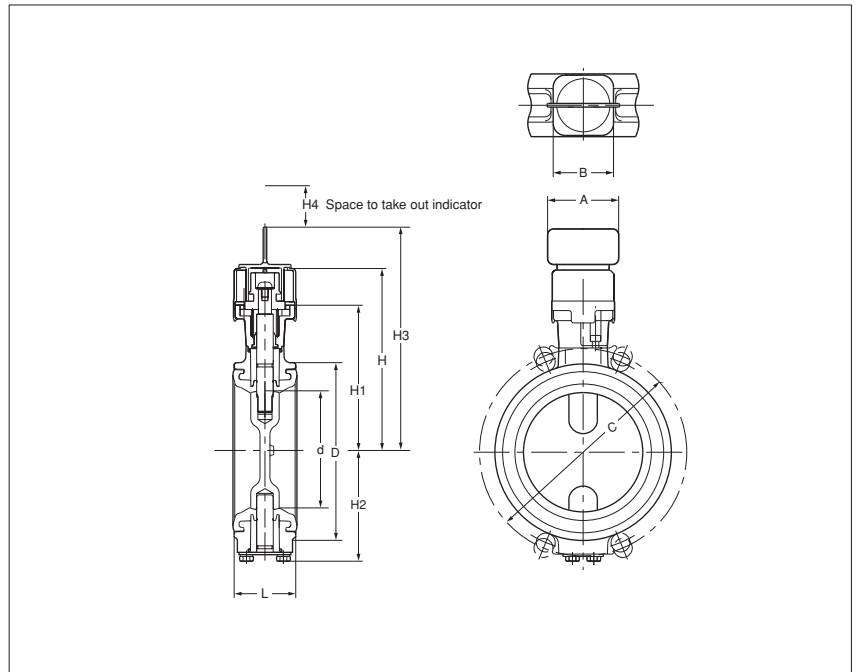

**Dimensions**

unit : mm

Size		d	H	H1	H2	H3	H4	L	D	C	A	B
mm	inch											
50	2	50	161	95	66	126	35	43	93	120	60	52
65	2½	65	169	103	74	134	35	46	118	140	60	52
80	3	80	178	112	83	143	35	46	129	150	60	52
100	4	100	189	123	94	154	35	52	149	175	60	52
125	5	125	224	151	122	175	35	56	184	210	60	73
150	6	150	237	163	135	187	35	56	214	240	60	73
200	8	196	263	190	161	214	35	60	258	290	60	73

**Operation of Neckless Type Valves**

No operation device is included for neckless type version.  
Use a socket wrench to open or close valves according to the following instructions.

**Operating procedure**

- 1 Disassemble an indicator from the top of a valve.
- 2 Apply a socket wrench on a hexagonal connector and push it down to unlock it.
- 3 Open or close the valve.
- 4 At the full open or closed position, the hexagonal connector rises and gets locked automatically.
- 5 Remove the socket wrench and mount the indicator.



Indicator



Hexagonal Connector



Socket wrench

**CAUTION**

Do not apply an excessive load on the indicator to protect it from damage or malfunction.

**Specification of socket wrench**

Valve size : 2" to 4"	180mm long × 24mm wide (Hexagonal)
Valve size : 5" and 6"	300mm long × 30mm wide (Hexagonal)
Valve size : 8"	600mm long × 30mm wide (Hexagonal)

**Long Neck Type**

**Pneumatically Operated-Double Action Actuator**

**FA-10XJME  
FA-10XJMEA**

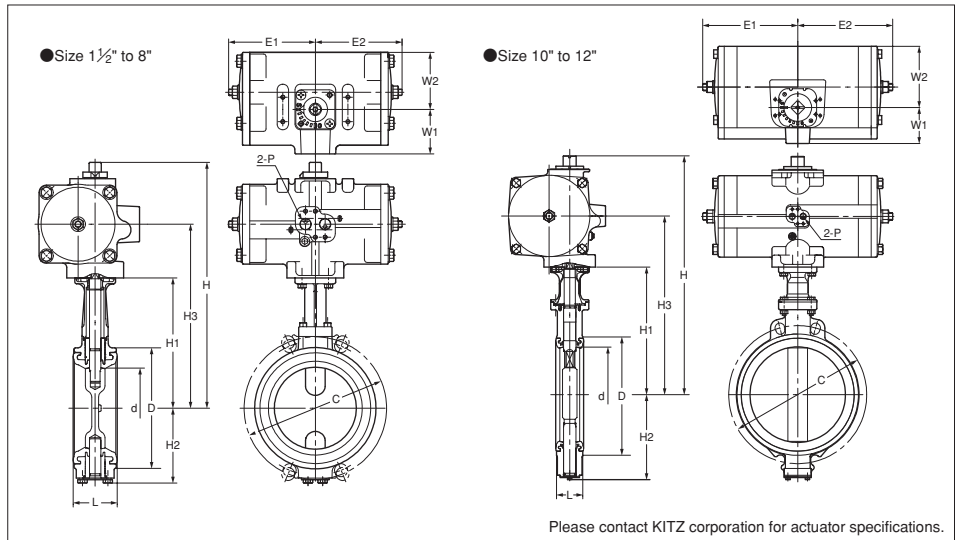

Please contact KITZ corporation for actuator specifications.

**Dimensions**

unit : mm

Size		d	H	H1	H2	H3	L	D	C		Actuator					
mm	inch								10K	Class150	E1	E2	W1	W2	P	Type
40	1 1/2	40	251	128	40	181	33	80	105	—	87	87	50	54	Rc 1/4	FA-1
50	2	50	255	132	66	185	43	93	120	120.5	87	87	50	54	Rc 1/4	FA-1
65	2 1/2	65	287	141	74	207	46	118	140	139.5	107	107	54	70	Rc 1/4	FA-2
80	3	80	295	149	83	215	46	129	150	152.5	107	107	54	70	Rc 1/4	FA-2
100	4	100	306	160	94	226	52	149	175	190.5	107	107	54	70	Rc 1/4	FA-2
125	5	125	357	195	122	271	56	184	210	216	128	128	57	87	Rc 1/4	FA-3
150	6	150	369	207	135	283	56	214	240	241.5	128	128	57	87	Rc 1/4	FA-3
200	8	196	435	234	161	327	60	258	290	298.5	160	160	68	111	Rc 1/4	FA-4
250	10	245	573	328	238	441	68	316	355	362	208	208	78	135	Rc 1/4	FA-5
300	12	295	627	353	263	475	78	367	400	—	268	268	101	178	Rc 1/4	FA-6

\*1 JIS 10K and ASME Class 150. Refer to Page 3 for details.

**Long Neck Type**

**Pneumatically Operated-Spring Return Action Actuator**

**FAS-10XJME  
FAS-10XJMEA**

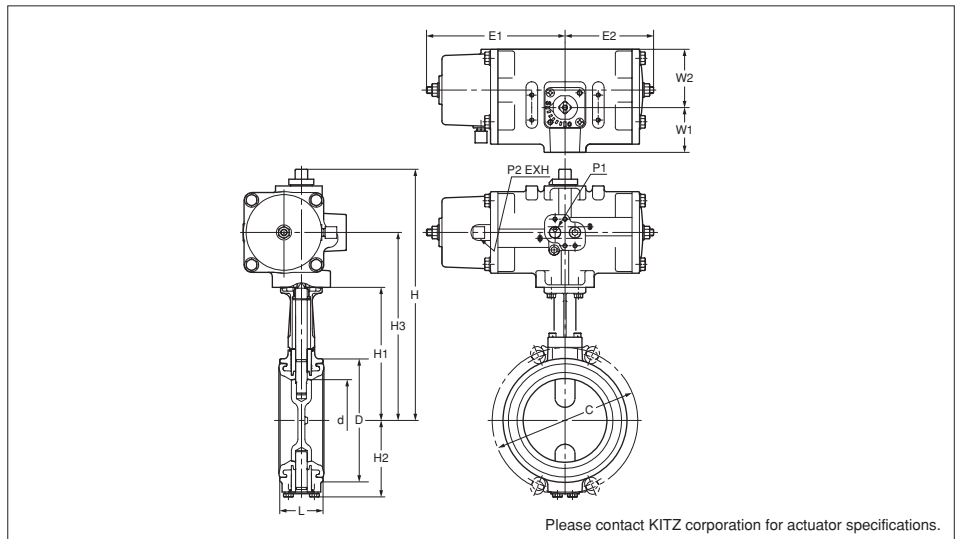

Please contact KITZ corporation for actuator specifications.

**Dimensions**

unit : mm

Size		d	H	H1	H2	H3	L	D	C		Actuator						
mm	inch								10K	Class150	E1	E2	W1	W2	P1	P2	Type
40	1 1/2	40	274	128	40	194	33	80	105	—	166	107	54	70	Rc 1/4	Rc 1/8	FAS-2
50	2	50	278	132	66	198	43	93	120	120.5	166	107	54	70	Rc 1/4	Rc 1/8	FAS-2
65	2 1/2	65	303	141	74	217	46	118	140	139.5	203	128	57	87	Rc 1/4	Rc 1/8	FAS-3
80	3	80	311	149	83	225	46	129	150	152.5	203	128	57	87	Rc 1/4	Rc 1/8	FAS-3
100	4	100	364	160	94	256	52	149	175	190.5	290	160	68	111	Rc 1/4	Rc 1/8	FAS-4
125	5	125	396	195	122	288	56	184	210	216	290	160	68	111	Rc 1/4	Rc 1/8	FAS-4
150	6	150	452	207	135	320	56	214	240	241.5	363	208	78	135	Rc 1/4	Rc 1/8	FAS-5
200	8	196	511	234	161	359	60	258	290	298.5	483	268	101	178	Rc 1/4	Rc 1/8	FAS-6

\*1 JIS 10K and ASME Class 150. Refer to Page 3 for details.

**Short Neck Type**

**Pneumatically Operated - Double Action Actuator**

**FA-10XJSME**

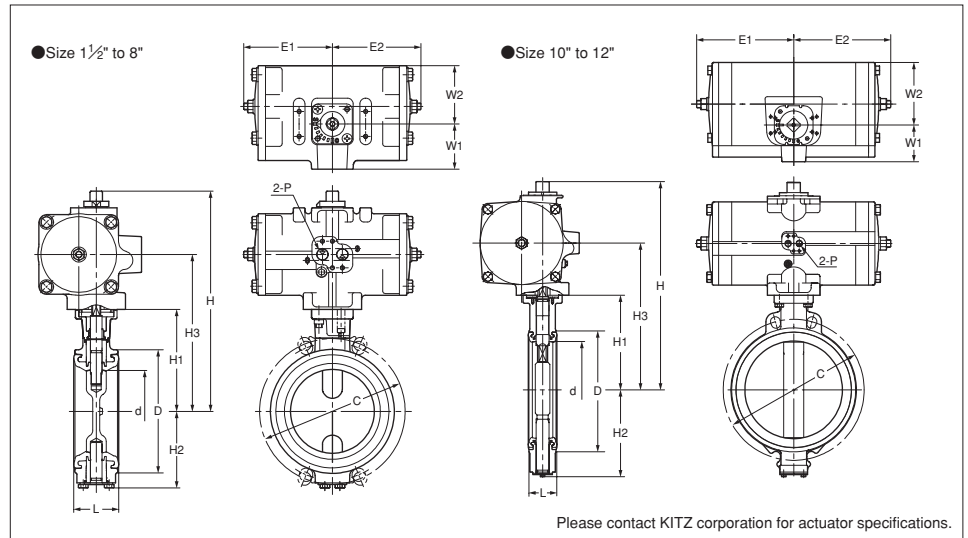

**Dimensions**

unit : mm

Size		d	H	H1	H2	H3	L	D	C	Actuator					Type
mm	inch									E1	E2	W1	W2	P	
40	1 1/2	40	216	93	40	146	33	80	105	87	87	50	54	Rc 1/4	FA-1
50	2	50	218	95	66	148	43	93	120	87	87	50	54	Rc 1/4	FA-1
65	2 1/2	65	249	103	74	169	46	118	140	107	107	54	70	Rc 1/4	FA-2
80	3	80	258	112	83	178	46	129	150	107	107	54	70	Rc 1/4	FA-2
100	4	100	269	123	94	189	52	149	175	107	107	54	70	Rc 1/4	FA-2
125	5	125	313	151	122	227	56	184	210	128	128	57	87	Rc 1/4	FA-3
150	6	150	325	163	135	239	56	214	240	128	128	57	87	Rc 1/4	FA-3
200	8	196	391	190	161	283	60	258	290	160	160	68	111	Rc 1/4	FA-4
250	10	245	483	238	238	351	68	316	355	208	208	78	135	Rc 1/4	FA-5
300	12	295	537	263	263	385	78	367	400	268	268	101	178	Rc 1/4	FA-6

**Short Neck Type**

**Pneumatically Operated - Spring Return Action Actuator**

**FAS-10XJSME**

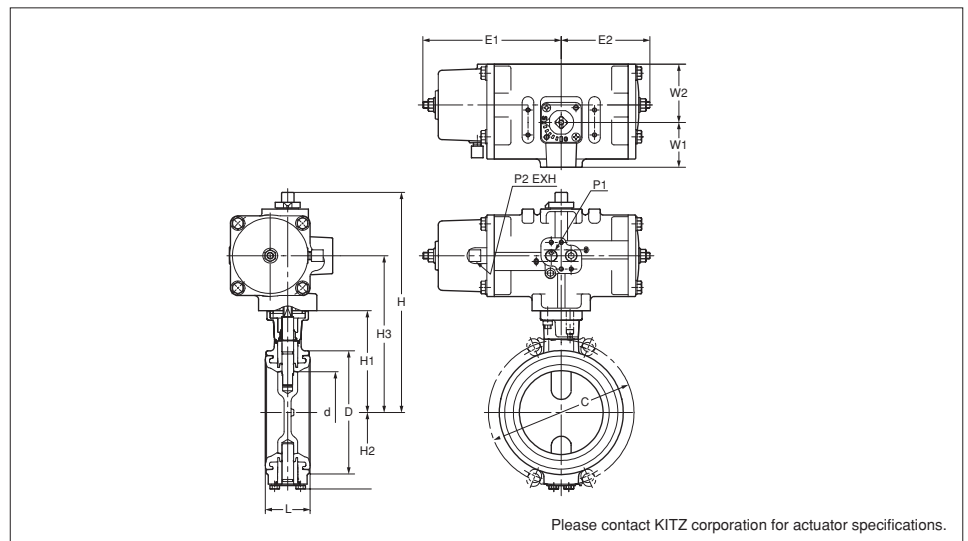

**Dimensions**

unit : mm

Size		d	H	H1	H2	H3	L	D	C	Actuator					Type	
mm	inch									E1	E2	W1	W2	P1		P2
40	1 1/2	40	239	93	40	159	33	80	105	166	107	54	70	Rc 1/4	Rc 1/8	FAS-2
50	2	50	241	95	66	161	43	93	120	166	107	54	70	Rc 1/4	Rc 1/8	FAS-2
65	2 1/2	65	265	103	74	179	46	118	140	203	128	57	87	Rc 1/4	Rc 1/8	FAS-3
80	3	80	274	112	83	188	46	129	150	203	128	57	87	Rc 1/4	Rc 1/8	FAS-3
100	4	100	327	123	94	219	52	149	175	290	160	68	111	Rc 1/4	Rc 1/8	FAS-4
125	5	125	352	151	122	244	56	184	210	290	160	68	111	Rc 1/4	Rc 1/8	FAS-4
150	6	150	408	163	135	276	56	214	240	363	208	78	135	Rc 1/4	Rc 1/8	FAS-5
200	8	196	467	190	161	315	60	258	290	483	268	101	178	Rc 1/4	Rc 1/8	FAS-6

**Long Neck Type**

*Electrically Operated*

**EXS-10XJME  
EXS-10XJMEA**



EXS-10XJME

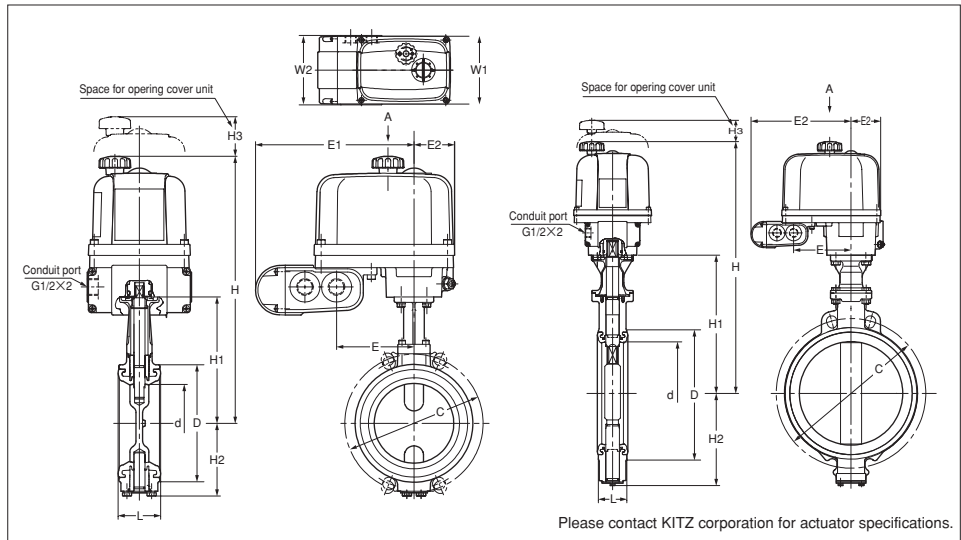

**Dimensions**

unit : mm

Size		d	H	H1	H2	L	D	C		Actuator					
mm	inch							10K	Class150	E1	E2	W1	W2	H3	Type
40	1½	40	309	128	40	33	80	105	—	98	206.5	131	132	107.5	EXS-2
50	2	50	313	132	66	43	93	120	120.5	98	206.5	131	132	107.5	EXS-2
65	2½	65	322	141	74	46	118	140	139.5	98	206.5	131	132	107.5	EXS-2
80	3	80	330	149	83	46	129	150	152.5	98	206.5	131	132	107.5	EXS-2
100	4	100	341	160	94	52	149	175	190.5	98	206.5	131	132	107.5	EXS-2
125	5	125	401	194.5	122	56	184	210	216	121.5	230	158	132	117.5	EXS-3
150	6	150	413.5	207	135	56	214	240	241.5	121.5	230	158	132	117.5	EXS-3
200	8	196	440	233.5	161	60	258	290	298.5	121.5	230	158	132	117.5	EXS-3
250	10	245	604	328	238	68	316	355	362	137	245.5	188	132	153	EXS-4
300	12	295	629	353	263	78	367	400	—	137	245.5	188	132	153	EXS-4

\*1 JIS 10K and ASME Class 150. Refer to Page 3 for details.

**Short Neck Type**

*Electrically Operated*

**EXS-10XJSME**

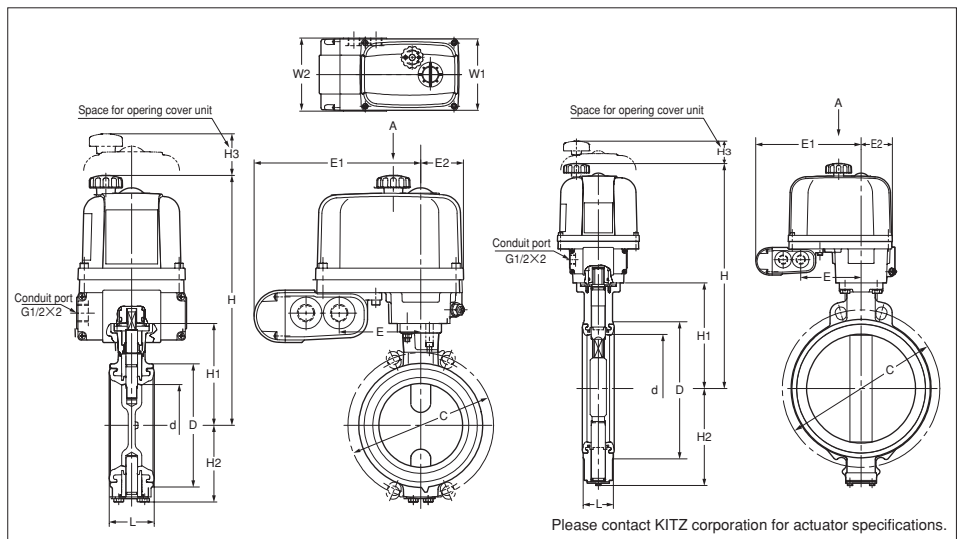

**Dimensions**

unit : mm

Size		d	H	H1	H2	L	D	C	Actuator					
mm	inch								E1	E2	W1	W2	H3	Type
40	1½	40	274	93	40	33	80	105	98	206.5	131	132	107.5	EXS-2
50	2	50	276	95	66	43	93	120	98	206.5	131	132	107.5	EXS-2
65	2½	65	284	103	74	46	118	140	98	206.5	131	132	107.5	EXS-2
80	3	80	293	112	83	46	129	150	98	206.5	131	132	107.5	EXS-2
100	4	100	304	123	94	52	149	175	98	206.5	131	132	107.5	EXS-2
125	5	125	357.5	151	122	56	184	210	121.5	230	158	132	117.5	EXS-3
150	6	150	369.5	163	135	56	214	240	121.5	230	158	132	117.5	EXS-3
200	8	196	396.5	190	161	60	258	290	121.5	230	158	132	117.5	EXS-3
250	10	245	514	238	238	68	316	355	137	245.5	188	132	153	EXS-4
300	12	295	539	263	263	78	367	400	137	245.5	188	132	153	EXS-4

## Pipes Recommended for Use of Butterfly Valves

When butterfly valves are being opened, move of discs may be interrupted by pipe internals. Where butterfly valves are connected with welded pipe flanges shown in the right illustration, use of pipes given in the right table is recommended. Valve-to-flange centering work must be always accurately done on valve mounting on pipelines.

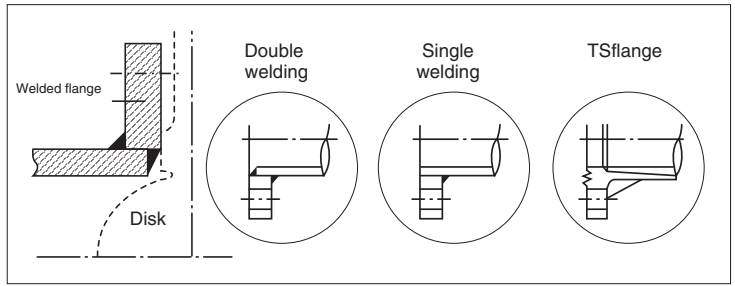

### Sizes of Lined Steel Pipes

In case of **vinyl chloride lined steel pipes**, sizes of flanges must be larger than the minimum inside diameters given in the right table. In case of pulverulent polyethylene of the pipes lined steel pipes, no special care is needed.

Pipe type		Double welding			Single welding			TS	Minimum Diam of pipe
mm	inch	SGP	Schedule		SGP	Schedule			
			20	40		20	40		
40	1½	●	—	●	●	—	●	●	28
50	2	●	●	●	●	●	●	●	30
65	2½	●	●	●	●	●	●	●	50
80	3	●	●	●	●	●	●	●	70
100	4	●	●	●	●	●	●	●	90
125	5	●	●	●	●	●	●	●	116
150	6	●	●	●	●	●	●	×	144
200	8	●	●	●	●	●	●	×	194
250	10	●	●	●	●	●	●	●	244
300	12	●	●	●	●	●	●	●	292

## Boltings Recommended for Use of Butterfly Valves (Boltings used for other than cast iron flanges)

### Hexagonal bolt

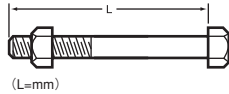

### Double bolt

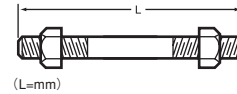

Flange		ASME class 150			EN1092 PN 16			JIS 10K		
mm	inch	Size	L	Pcs.	Size	L	Pcs.	Size	L	Pcs.
40	1½	—	—	—	—	—	—	M16	85	4
50	2	⅝-11	100	4	M16	105	4	M16	95	4
65	2½	⅝-11	105	4	M16	110	4	M16	105	4
80	3	⅝-11	110	4	M16	110	8	M16	105	8
100	4	⅝-11	125	8	M16	115	8	M16	110	8
125	5	¾-10	130	8	M16	120	8	M20	120	8
150	6	¾-10	135	8	M20	125	8	M20	125	8
200	8	¾-10	145	8	M20	130	12	M20	130	12
250	10	⅞-9	160	12	—	—	—	M22	150	12
300	12	—	—	—	—	—	—	M22	160	16

Flange		ASME Class 150			EN1092 PN 16			JIS 10K		
mm	inch	Size	L	Pcs.	Size	L	Pcs.	Size	L	Pcs.
40	1½	—	—	—	—	—	—	M16	105	4
50	2	⅝-11	120	4	M16	125	4	M16	115	4
65	2½	⅝-11	130	4	M16	130	4	M16	120	4
80	3	⅝-11	130	4	M16	130	8	M16	120	8
100	4	⅝-11	145	8	M16	135	8	M16	130	8
125	5	¾-10	160	8	M16	140	8	M20	145	8
150	6	¾-10	160	8	M20	145	8	M20	150	8
200	8	¾-10	170	8	M20	155	12	M20	155	12
250	10	⅞-9	190	12	—	—	—	M22	170	12
300	12	—	—	—	—	—	—	M22	180	16

★ Please contact KITZ Corporation when cast iron flanges are used.



# Precautions for Trouble-free Operation of KITZ Butterfly Valves

## Valve Selection

- 1 Ensure to select a valve with design specifications which meet the fluid type and the pressure and temperature conditions required.
- 2 Lubricants are applied to discs and rubber seats as standard to protect their surfaces. Oil-free treated types are available as option. Contact KITZ Corporation or its local distributors for the details.
- 3 Contact KITZ Corporation or its local distributors for service with pulverulent bodies.

## Storage and Handling

- 1 Valves must be stored in dry, clean and corrosion-free environment with no direct exposure to the sun, leaving valves open by 10° for prevention of permanent distortion of resilient seats. Refrain from overloading valves and their actuators, such as storing them in piles or placing other objects on them.

## Mounting on Pipelines

- 1 Valves must be mounted on flanges only after flanges have been welded to pipes and cooled down to the atmospheric temperature. Otherwise, welding heat may affect the quality of resilient seats.
- 2 Edges of welded flanges must be machined for smooth surface finish so that they may not damage resilient seats during valve mounting. Flange faces must be free from damage or deformation, and be cleaned to remove rust or any other foreign objects so that there will be no concern of external leakage through valve and flange connections. Gaskets are not required for mounting KITZ XJ series butterfly valves.
- 3 Clean flanges and pipe bores to thoroughly remove welding spatters, scales and other foreign objects which may have been left inside.
- 4 Accurate centering of each couple of upstream and downstream pipes is essential for trouble-free operation of valves mounted between them. Incorrect centering shown in Fig.1 must be by all means avoided.

Fig.1

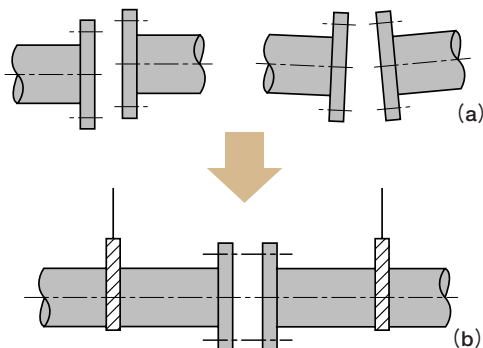

- 5 For valve mounting, set jack bolts under the pipes for flat support at the same height, and adjust the flange-to-flange distance so that some 6mm to 10mm room may be allowed beside the both sides of the valve body. Remember that valves here must be left open only by 10 from the fully closed position. (Fig.2)
- 6 Set two bolts into the lower mounting guides of a valve and mount it carefully so that flange faces may not damage resilient seats.
- 7 Then set another two bolts into the upper mounting guides of a valve, ensuring the correct centering between pipes and the valve.
- 8 Trial open the valve to check to see if there is no disturbing contact between the valve disc and the flanges.
- 9 Remove the jack bolts, set all bolts around the valve body and tighten them alternately and diagonally. Till the flanges contact the valve body (Fig.3). Refer to the table shown below for recommended torque values.

Fig.2

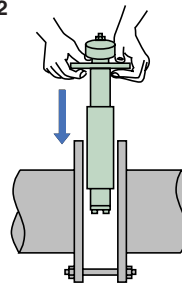

Recommended torque values

DN	N · m (kgf · m)
40	49(5)
50	
65	
80	
100	
125	88(9)
150	
200	
250	118(12)
300	

Fig.3

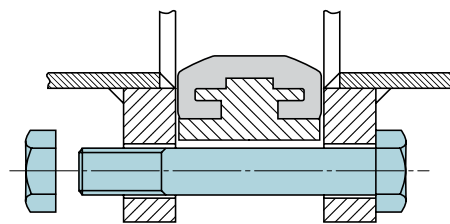

- 10 For mounting actuated valves, provide valve supports to prevent bending of valve necks and reduce valve and pipe vibration.
- 11 Don't step on valve necks or valve hand-wheels.
- 12 Don't mount butterfly valves directly to check valves or pumps, which may cause damage to them by the disc contacts.
- 13 Don't mount valves to downstream sides of elbows, reducers or regulating valves where fluid velocity changes. It is re-recommended to install valves approximately 10 times of the valve nominal sizes away from them for such cases.

- 14 Mount valves taking consideration of the effects which discs are given by fluid velocity or pressure changes in the pipings. Refer to the illustrations. (Fig.4)  
Contact KITZ Corporation or its local distributors for the details.

Fig.4

●Mounting to bent pipe

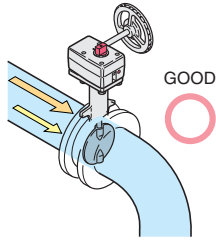

●Mounting to pump outlet

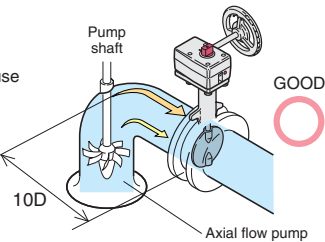
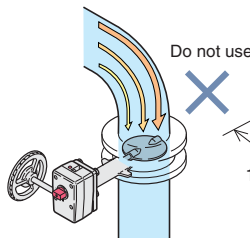
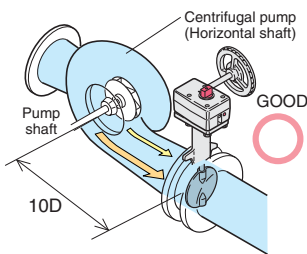
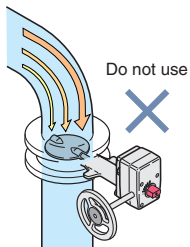
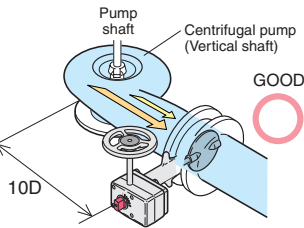

**Note:**  
Centering with centering sleeves is required for the valves coupled with them for accurate centering (Fig.5)  
Refer to page 3 for applicable sizes.

Fig.5

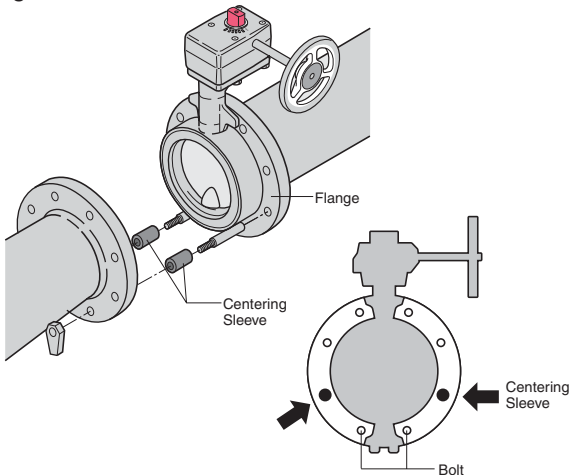

## Valve Operation

- 1 Valves equipped with manual operators such as levers, handles and gears must be ONLY MANUALLY operated. Application of an excessive external force to operate valves may result in malfunction of valves and their operators.
- 2 Ensure to fully open valves before a loop test of the piping system is carried out with line pressure higher than the nominal pressure of tested valves. Never use closed valves in place of blind flanges.
- 3 When valves need to be dismantled from pipes for maintenance or any other cause, ensure to thoroughly release the line pressure beforehand. Loosening piping bolts under line pressure causes a danger. Any residual fluid left inside the pipeline must be completely drained.
- 4 Users should contact KITZ Corporation or its local distributors for technical advice, when valves should be continuously pressurized while left open by 30° or less.
- 5 Don't use position indicators to operate valves, or overload position indicators. This may cause damage to indicators.
- 6 Ensure to use blind flanges when butterfly valves are mounted at the end of pipelines.
- 7 Standard actuators are referenced in this catalog for actuated valve operation. Contact KITZ Corporation or its local distributors for mounting optional actuators.
- 8 Contact KITZ Corporation for service at hopper or pump outlets.
- 9 Avoid touching gear operators and actuator stopper bolts accidentally.
- 10 It is recommended to perform periodical inspection for
  - Making sure of valve opening degree
  - Checking loosened bolts and leakage at each connection
  - Checking vibration and noise
- 11 Refer to instruction manual for other precautions. Also refer to actuator catalogs and instruction manuals for actuated valves.

## WARNING

Don't disassemble necks while the valve is pressurized to prevent stem blow-out. Also don't dismantle valve operating devices, since it may cause valve discs rotate and result valve malfunction.

## CAUTION

Pressure-temperature ratings and other performance data published in this catalog have been developed from our design calculation, in-house testing, field reports provided by our customers and/or published official standards or specifications. They are good only to cover typical applications as a general guideline to users of KITZ products introduced in this catalog.

For any specific application, users are kindly requested to contact KITZ Corporation for technical advice, or to carry out their own study and evaluation for proving suitability of these products to such an application. Failure to follow this request could result in property damage and/or personal injury, for which we shall not be liable.

While this catalog has been compiled with the utmost care, we assume no responsibility for errors, impropriety or inadequacy. Any information provided in this catalog is subject to from-time-to-time change without notice for error rectification, product discontinuation, design modification, new product introduction or any other cause that KITZ Corporation considers necessary. This edition cancels all previous issues.

Read instruction manual carefully before use.

## NOTICE

If any products designated as strategic material in the Foreign Exchange and Foreign Trade Law, Cabinet Order Concerning Control of Export Trade, Cabinet Order Concerning Control of Foreign Exchange and other related laws and ordinances ("Foreign Exchange Laws") are exported to any foreign country or countries, an export license issued by the Japanese Government will be required under the Foreign Exchange Laws.

Further, there may be cases where an export license issued by the government of the United States or other country will be required under the applicable export-related laws and ordinances in such relevant countries.

The contract shall become effective subject to that a relevant export license is obtained from the Japanese Government.



*A chrysanthemum-handle is a symbol of KITZ,  
the brand of valve reliability*

ISO 9001 certified since 1989

**KITZ**  
KITZ CORPORATION

1-10-1, Nakase, Mihama-ku, Chiba 261-8577, Japan  
International Sales Dept. Phone : 81-43-299-1730, 1732 and 1733  
Fax : 81-43-299-0121

— Distributed by —